



2024 SECOND SEMESTER FINAL EXAMINATIONS

Faculty	:	Engineering and the Environment
Department	:	Metallurgical Engineering
Paper Code/Title	:	EMG 2202/Solid Mechanics
Duration	:	3 Hours
Examiner	:	P. Garanowako
Authorized material	:	calculator, list of formulae

INSTRUCTIONS

1. This paper contains **one** section with **six** questions.
2. Answer any **four** questions.
3. Where the question contains subdivisions, the mark of each subdivision is shown in brackets.
4. Each question carries **25 marks**.
5. Start each question on a new page.

NB: DO NOT TURN OVER THE QUESTION PAPER OR COMMENCE WRITING UNTIL INSTRUCTED TO DO SO

Question 1

- a. Define the following terms
- i. Allowable load [1 mark]
 - ii. Allowable stress [1 mark]
 - iii. Safety factor [2 marks]
- b. The selection of the factor of safety for various engineering applications is a critical task. If the factor of safety is chosen too small, the risk of failure becomes unacceptably high. Conversely, if the factor of safety is unnecessarily large, it leads to an uneconomical or nonfunctional design. What considerations are involved in choosing the appropriate factor of safety for a given design application? [6 marks]
- c. In figure 1 below, when the force P reached 8 kN, the wooden specimen shown failed in shear along the surface indicated by the dashed line. Determine the average shearing stress along that surface at the time of failure. [5 marks]

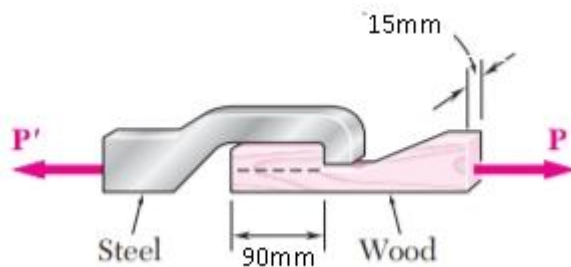

Figure 1

- d. Two solid cylindrical rods AB and BC are welded together at B and loaded as shown in Figure 2. Given that the average normal stress must not exceed 175 MPa in rod AB and 150 MPa in rod BC, determine the smallest allowable values of d_1 and d_2 . [10 marks]

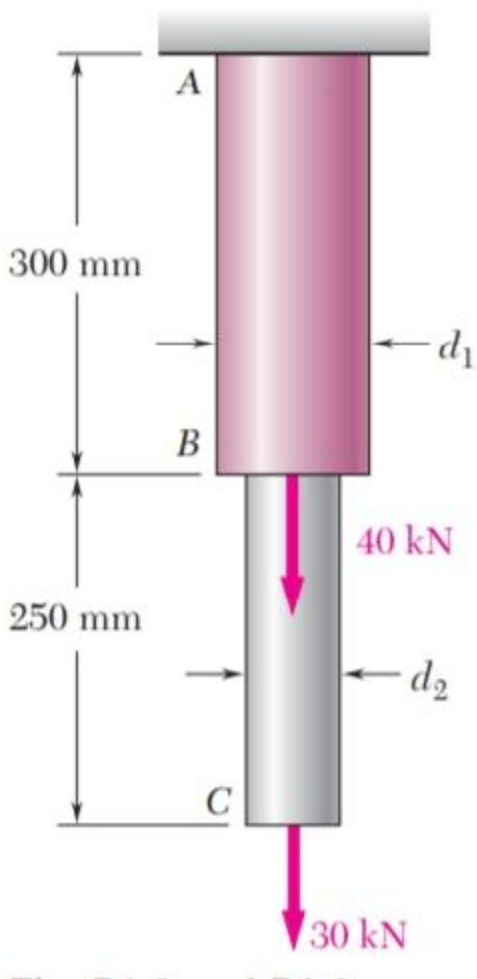

Figure 2

Question 2

- a. A steel rod has a diameter of 10mm and length of 2mm. it is stretched with a force of 20 kN and extends 0.2mm. calculate the
 - i. nominal stress **[2 marks]**
 - ii. nominal strain **[2 marks]**
 - iii. true stress **[4 marks]**
 - iv. true strain **[4 marks]**
- b. Comment on the differences between the nominal and true values of the above calculated values if any. **[3 marks]**

- c. A 10 mm diameter Brinnell hardness indenter produced an indentation of 2.50 mm in diameter in steel alloy when a load 1000kg was used. Compute the HB of this material. **[5 marks]**
- d. What will be the diameter of an indentation to yield a hardness of 300 HB when a 400 kg load is used? **[5 marks]**

Question 3

- a. A specimen of steel 20 mm diameter with a gauge length of 200 mm is tested to destruction. It has an extension of 0.25 mm under a load of 80 kN and the load at elastic limit is 102 kN. The maximum load is 130 kN.

The total extension at fracture is 56 mm and diameter at neck is 15 mm. Find

- (i) The stress at elastic limit.
 - (ii) Young's modulus.
 - (iii) Percentage elongation.
 - (iv) Percentage reduction in area.
 - (v) Ultimate tensile stress. **[10 marks]**
- b. Figure 3. Shows stress *vs* strain diagram for the typical mild steel specimen. State and explain the following salient points(A,B,C,D,E) which are observed on stress-strain curve: **[12 marks]**

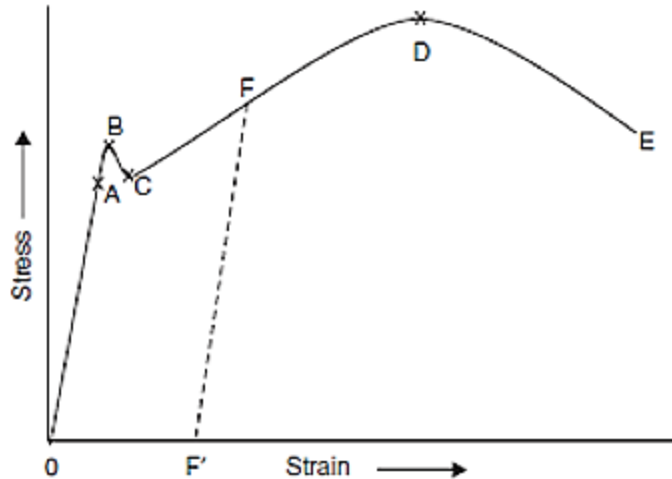

Figure 3

- c. Describe the differences between failure by fracture and failure by yielding. [3marks]

Question 4

- a. What are the different failure modes associated with torsional loading? [5 marks]
- b. Given that the internal diameter of a hollow shaft shown in Figure 4.1 is $d = 40\text{mm}$,
- Determine the maximum shearing stress caused by a torque of magnitude $T = 90\text{ Nm}$. [5 marks]
 - Given that $d = 25\text{mm}$, determine the torque T which causes the maximum shear stress of 21 KN in the hollow shaft shown in Figure 4.1. [5 marks]

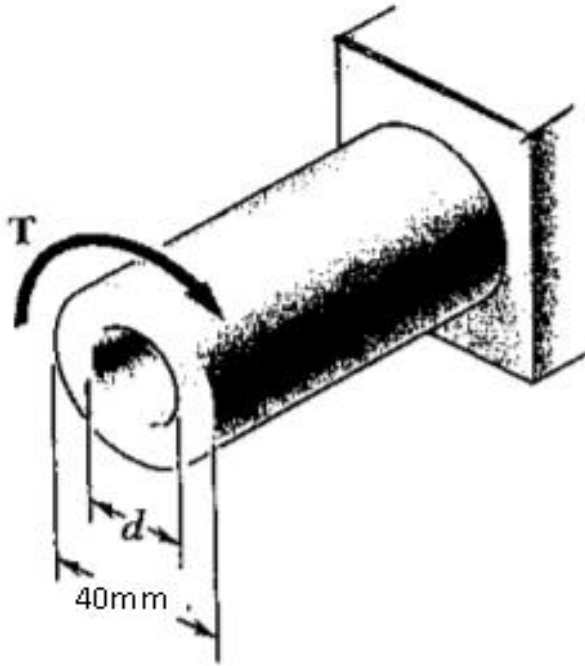

Figure 4.1

- c. A hollow cylindrical steel shaft is 1.5 m long and has inner and outer diameters respectively equal to 40 and 60 mm (Figure. 4.2).
- (i) What is the largest torque that can be applied to the shaft if the shearing stress is not to exceed 120 MPa? **[5 marks]**
 - (ii) (ii) What is the corresponding minimum value of the shearing stress in the shaft? **[5 marks]**

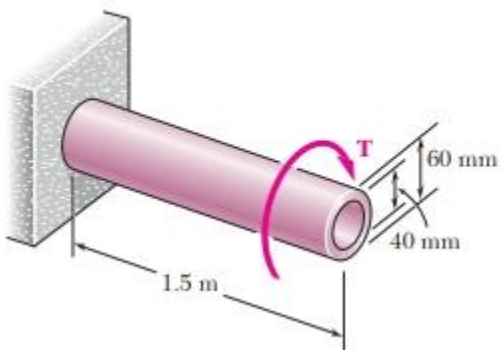

Figure 4.2

Question 5

- a. What are the limitations of the theory of pure bending? **(5 marks)**
- b. Two equal and opposite couples of magnitude $M = 25 \text{ kN.m}$ are applied to the channel-shaped beam AB as shown in Figure 5. Observing that the couples cause the beam to bend in a horizontal plane, determine the stress at
- (i) point C,
 - (ii) point D,
 - (iii) point E.
- (20 marks)**

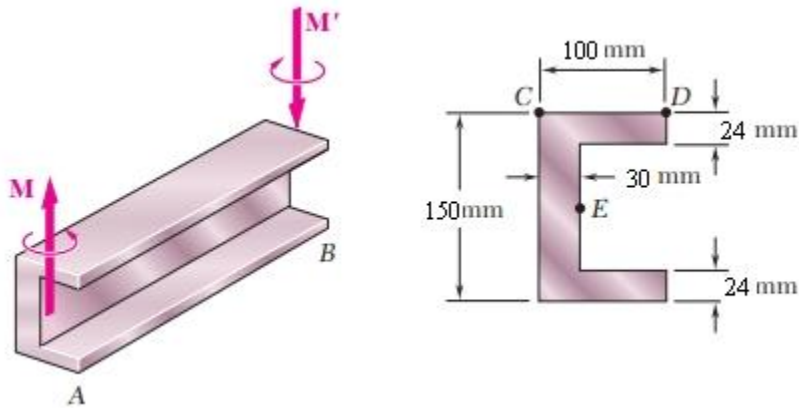

Figure 5

Question 6

- a. Draw the shear and bending-moment diagrams for the following
- (i) a simply supported beam AB of span L subjected to a single concentrated load P at its midpoint C (Figure 6.1) **(5 marks)**

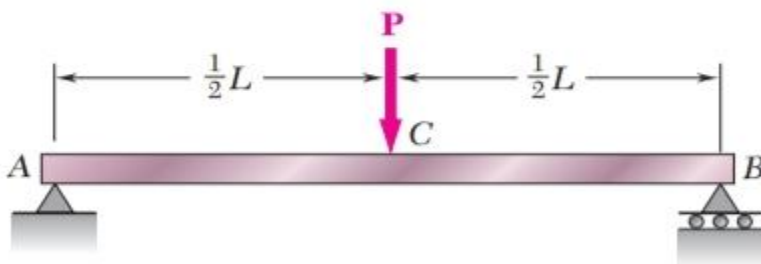

Figure 6.1

- (ii) a cantilever beam AB of span L supporting a uniformly distributed load w (Fig. 6.2). **(5 marks)**

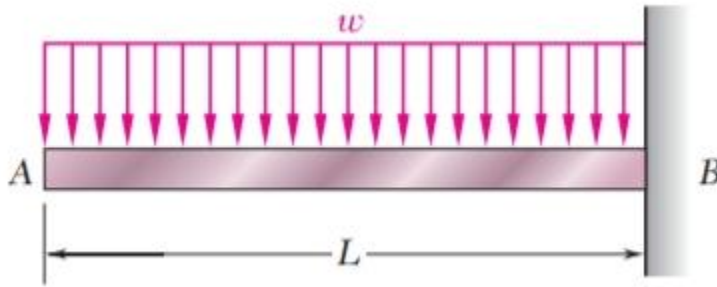

Figure 6.2

- b. For the timber beam and loading shown in Figure 6.3, draw the shear and bending-moment diagrams and determine the maximum normal stress due to bending **(15 marks)**

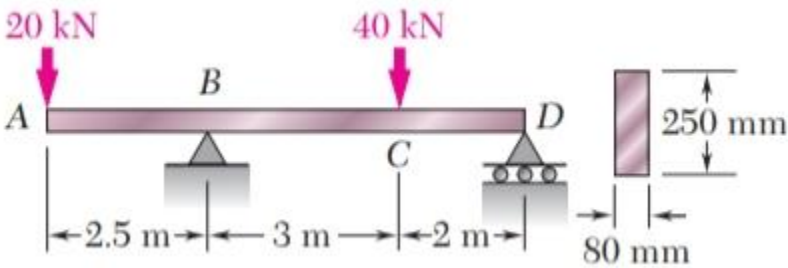

Figure 6.3