



2025 SECOND SEMESTER FINAL EXAMINATIONS

Faculty	:	Engineering and the Environment
Department	:	Metallurgical Engineering
Paper Code/Title	:	EMG 2202/Solid Mechanics
Duration	:	3 Hours
Examiner	:	P. Garanowako
Authorized material	:	Calculator, Math set, Graph paper

INSTRUCTIONS

1. This paper contains **one** section with **Five** questions.
2. Answer any **four** questions.
3. Where the question contains subdivisions, the mark of each subdivision is shown in brackets.
4. Each question carries **25 marks**.
5. Start each question on a new page.

NB: DO NOT TURN OVER THE QUESTION PAPER OR COMMENCE WRITING UNTIL INSTRUCTED TO DO SO

Question 1

- a. Two wooden members of uniform cross section are joined by the simple scarf splice shown in Fig1. Knowing that the maximum allowable tensile stress in the glued splice is 500 kPa, determine :(i) the largest load P that can be safely supported. [5]
(ii) the corresponding shearing stress in the splice. [5]

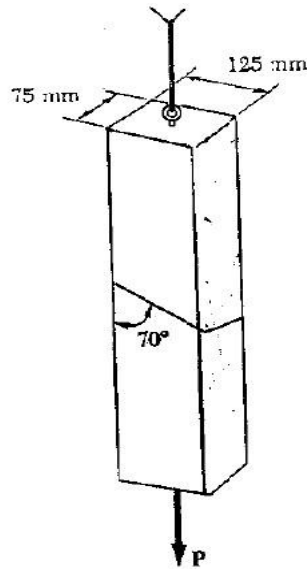

Fig 1

- b. The wooden members A and B are to be joined by plywood splice plates that will be fully glued on the surfaces in contact as shown in Fig 2. As part of the design of the joint, and knowing that the clearance between the ends of the members is to be 8 mm, determine the smallest allowable length L if the average shearing stress in the glue is not to exceed 800 kPa. [7]

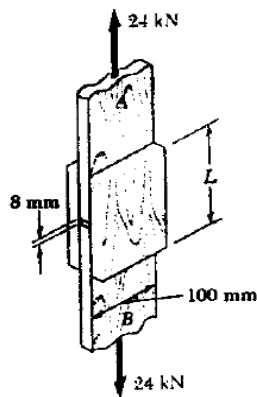

Fig 2

- c. A steel rod has a diameter of 10mm and length of 2m. it is stretched with a force of 20 kN and extends 0.2m. calculate the
- i. true stress [4]
 - ii. true strain [4]

Question 2

- a. With the aid of diagrams, explain the Saint-Venant's principle [5]
- b. A standard tension test is used to determine the properties of an experimental plastic material. The test specimen is a 15 mm diameter rod and it is subjected to a 3.5 KN tensile force. Knowing that elongation of 11 mm and a decrease in diameter of 0.62mm are observed in a 120 mm gage length, determine the modulus of elasticity, modulus of rigidity, and Poisson's ratio of the material. [12]
- c. Describe the procedure for carrying out a tensile test on a steel specimen to determine its yield strength in a controlled laboratory environment. [8]

Question 3

- a. Derive the elastic torsion formulas [7]
- b. Shaft *BC* is hollow with inner and outer diameters of 90 mm and 120 mm, respectively. Shafts *AB* and *CD* are solid and of diameter *d*. For the loading shown in Fig 3, determine
 - (i) the maximum and minimum shearing stress in shaft *BC* [10]
 - (ii) the required diameter *d* of shafts *AB* and *CD* if the allowable shearing stress in these shafts is 65 MPa. [8]

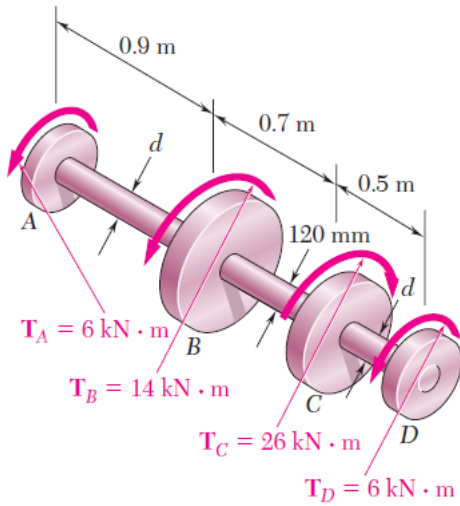

Fig 3

Question 4

- a. Draw the shear and bending-moment diagrams for the loading in Fig 4 and then determine the equations of the shear and bending moment curves for the loading.[10]

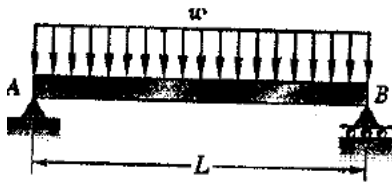

Fig 4

- b. Draw the shear and bending-moment diagrams for the loading shown in Fig 5 and determine the absolute value of (i) the shear [8]
(ii) the bending moment [7]

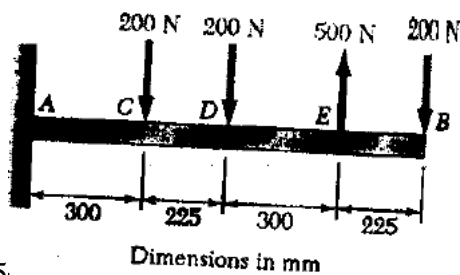

Fig 5

Question 5

- a. For the given state of stress in Fig 6, (i) Draw the Mohr's circle, (ii) determine the principal planes, (iii) determine the principal stresses, (iv) determine the maximum shearing stress and the corresponding normal stress. [20]

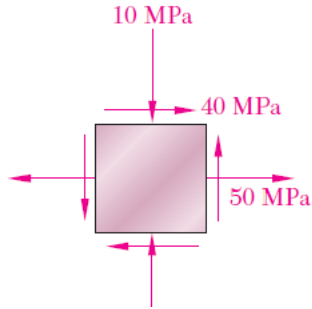

Fig 6

- b. What are the limitations of the theory of pure bending? [5]