



## SUPPLEMENTARY EXAMINATIONS

SEPTEMBER 2025

Faculty	:	Engineering and the Environment
Department	:	Metallurgical Engineering
Paper Code/Title	:	EMG 2202/Solid Mechanics
Duration	:	3 Hours
Examiner	:	P. Garanowako
Authorized material	:	Calculator, Math set, Graph paper.

## INSTRUCTIONS

1. This paper contains **one** section with **six** questions.
2. Answer any **four** questions.
3. Where the question contains subdivisions, the mark of each subdivision is shown in brackets.
4. Each question carries **25 marks**.
5. Start each question on a new page.

**NB: DO NOT TURN OVER THE QUESTION PAPER OR COMMENCE WRITING UNTIL INSTRUCTED TO DO SO**

Question 1

- a. The steel tie bar shown in Fig 1 is to be designed to carry a tension force of magnitude  $P = 120 \text{ MPa}$  when bolted between double brackets at  $A$  and  $B$ . The bar will be fabricated from 20-mm-thick plate stock. For the grade of steel to be used, the maximum allowable stresses are: normal stress = 175 MPa, shearing stress = 100 MPa and bearing stress = 350 MPa

Design the tie bar by determining the required values of:

- (i) the diameter  $d$  of the bolt, [6]
- (ii) the dimension  $b$  at each end of the bar, [6]
- (iii) the dimension  $h$  of the bar. [6]

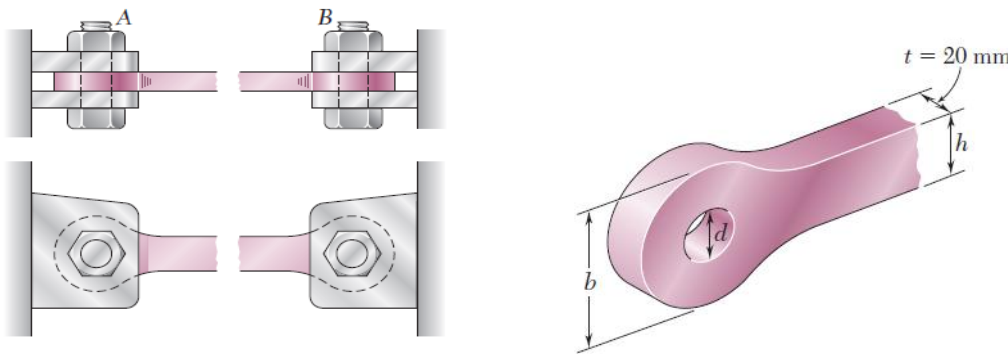

Fig 1

- b. The selection of the factor of safety for various engineering applications is a critical task. If the factor of safety is chosen too small, the risk of failure becomes unacceptably high. Conversely, if the factor of safety is unnecessarily large, it leads to an uneconomical or nonfunctional design. What considerations are involved in choosing the appropriate factor of safety for a given design application? [7]

Question 2

- a. Define true stress and true strain, explaining how they differ from nominal stress and strain respectively [5]
- b. Determine the deformation of the steel rod shown in Fig. 2. under the given loads ( $E = 29 \times 10^6 \text{ Pa}$ ). [10]

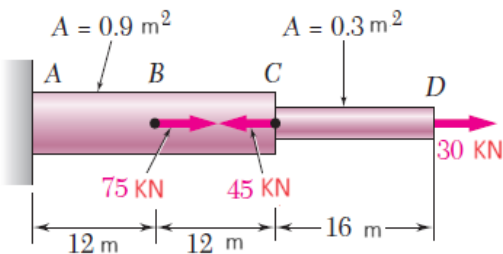

Fig 2

- c. A 500-mm-long, 16-mm-diameter rod made of a homogenous, isotropic material is observed to increase in length by  $300 \times 10^{-6}$  m and to decrease in diameter by  $2.4 \times 10^{-6}$  m when subjected to an axial 12-kN load. Determine the modulus of elasticity and Poisson's ratio of the material. [10]

Question 3

- a. Differentiate between torque and torsion. [5]
- b. The torques shown in Fig 3 are exerted on pulleys A and B. Knowing that each shaft is solid, determine the maximum shearing stress (i) in shaft AB, (ii) in shaft BC. [10]

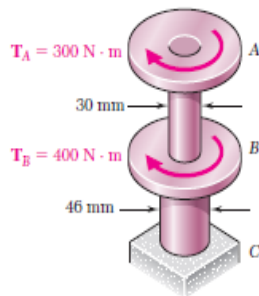

Fig 3

- c. (i) determine the torque which may be applied to a solid shaft of 0.075m diameter without exceeding an allowable shearing stress of 10 KPa. [5]
- (ii) solve part (i) assuming that the solid shaft has been replaced by a hollow shaft of the same cross sectional area and with an inner diameter equal to half of its outer diameter. [5]

Question 4

- a. Derive the equations of pure bending stating the underlying assumptions. [10]
- b. A cast-iron machine part is acted upon by the 3 kN.m couple shown in Fig 4. Knowing that  $E = 65 \text{ GPa}$  and neglecting the effect of fillets, determine: (i) the maximum tensile and compressive stresses in the casting. [10]
- (ii) the radius of curvature of the casting. [5]

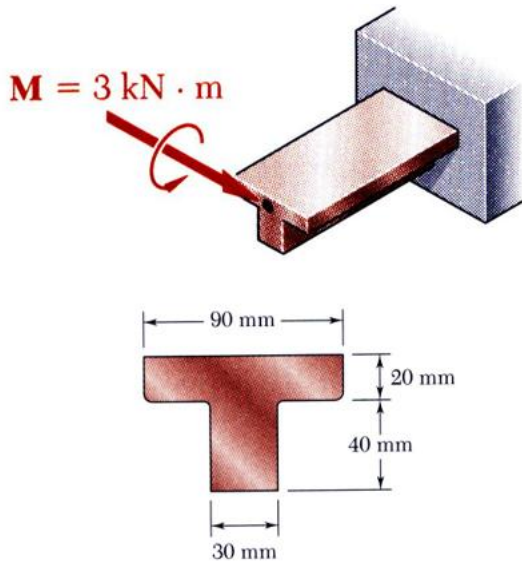

Fig 4

Question 5

- a. For the given state of stress in Fig 5, (i) Draw the Mohr's circle. (ii) determine the principal planes, (iii) determine the maximum in plane shearing stress, (iv) determine the corresponding normal stress. [20]

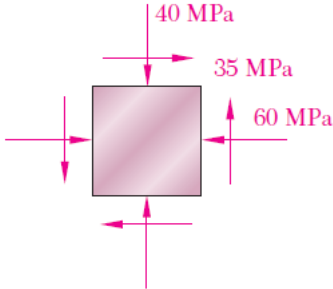

Fig 5

- b. Draw the shear and bending-moment diagrams for the following
- (i) a simply supported beam AB of span L subjected to a single concentrated load P at its midpoint C(Fig 6) [5]

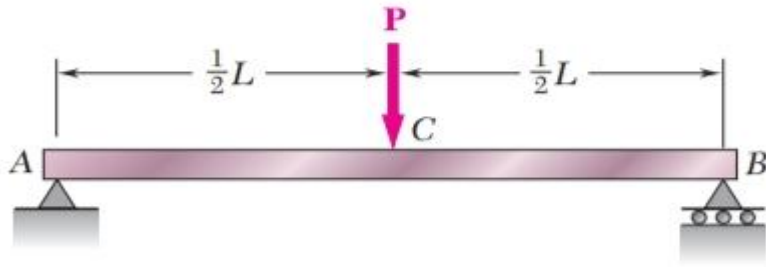

Fig 6